

30° Asymmetrical Beam Antenna

HORN ANTENNA WITH TWISTPORT™ CONNECTOR

30° Asymmetrical Horn TP Antenna has high gain and zero side lobes, meaning very high beam efficiency. Its radiation pattern is wide in the azimuth and narrow in the elevation plane. The stability of gain, radiation pattern, and resulting coverage is excellent across the whole useful bandwidth. These properties and outstanding noise rejection favor 30° Asymmetrical Horn TP Antenna to be used in high customer density and co-location sites. TwistPort™ - our revolutionary patent-pending twist-and-lock waveguide port enables connectivity to a wide range of third-party radios using TwistPort™ Adaptors.

BeamSwitch™ feature enables mounting of the antenna with 90° rotation by swapping the position of the handle and the bracket. AH2030-TP thus can provide 20° azimuth and 30° elevation beamwidth option. The extruded aluminium ring improves the structural strength of the antenna attachment and makes the BeamSwitch™ flip easy and fast.



TECHNICAL DATA

Antenna Connection	TwistPort™ - Quick Locking Waveguide Port
Antenna Type	Horn
Materials	UV Resistant ABS Plastic, Polycarbonate, HDPE, Aluminium, Stainless Steel
Environmental	IP55
Pole Mounting Diameter	40-80 mm (we recommend as close to 80mm as possible)
Temperature	-35°C to +60°C (-31°F to +140°F)
Wind Survival	160 km/hour
Wind Loading	67 N at 160km/h
Mechanical Adjustment	± 20° Elevation, ± 20° Azimuth
Weight	4.2 Kg / 9.2 lbs – single unit* 6.3 Kg / 13.8 lbs – single unit incl. package*
Single Unit	Retail Box: 483 x 334 x 235 mm / 19.0 x 13.1 x 9.2 inch*

PERFORMANCE

Frequency Range	5180 - 6000 MHz
Gain	20.5 dBi
Azimuth Beam Width -3 dB	H 21° / V 21°
Elevation Beam Width -3 dB	H 15° / V 15°
Azimuth Beam Width -6 dB	H 30° / V 30°
Elevation Beam Width -6 dB	H 20° / V 20°
Beam Efficiency**	95%
Front-to-Back Ratio	35 dB

PRODUCT DIMENSIONS

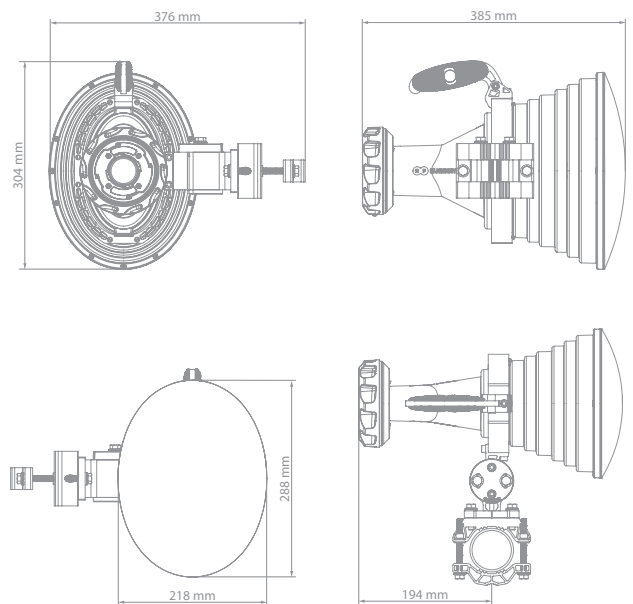

AZIMUTH PATTERN

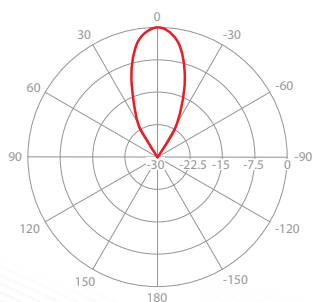

V/H - Port Pattern Azimuth 5.6 GHz

ELEVATION PATTERN

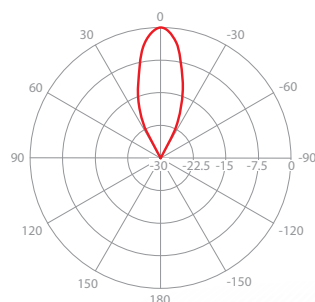

V/H - Port Pattern Elevation 5.6 GHz

GAIN

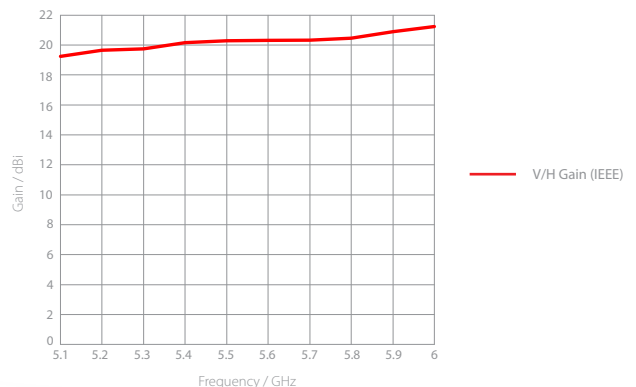

*Subject to change **Beam efficiency defined up to first null

3D RADIATION DIAGRAM

SCALE: 30dBi

COMPATIBLE WITH: ADOBE ACROBAT READER DC. NOT SUPPORTED ON MOBILE.

USE MOUSE TO ROTATE THE DIAGRAM. SCROLL IN/OUT TO ZOOM IN/OUT

dBi

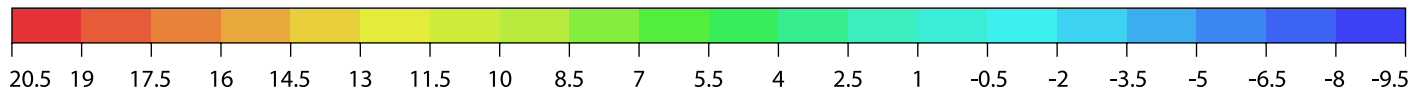

FRONT	BACK	RIGHT	LEFT	UP	DOWN
-------	------	-------	------	----	------